

7



INSERTI PER TUBI

INSERTS FOR TUBES

GEWINDEEINSÄTZE FÜR ROHRE

INSERTS POUR LES TUBES

INSERTOS PARA TUBOS

FIXI®

FASTENING SYSTEMS

Member of CISQ Federation



Il laboratorio Fixi garantisce la conformità dei prodotti grazie ad accurati test interni con macchinari di ultima generazione.

Fixi carries out accurate testing in its own lab equipped with the latest generation machinery to ensure product conformity.

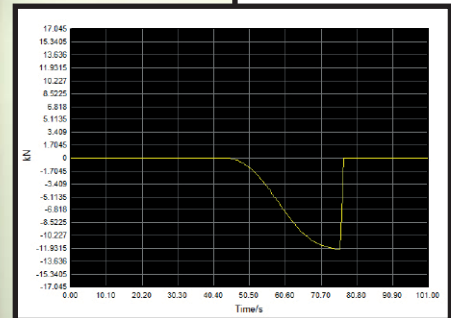
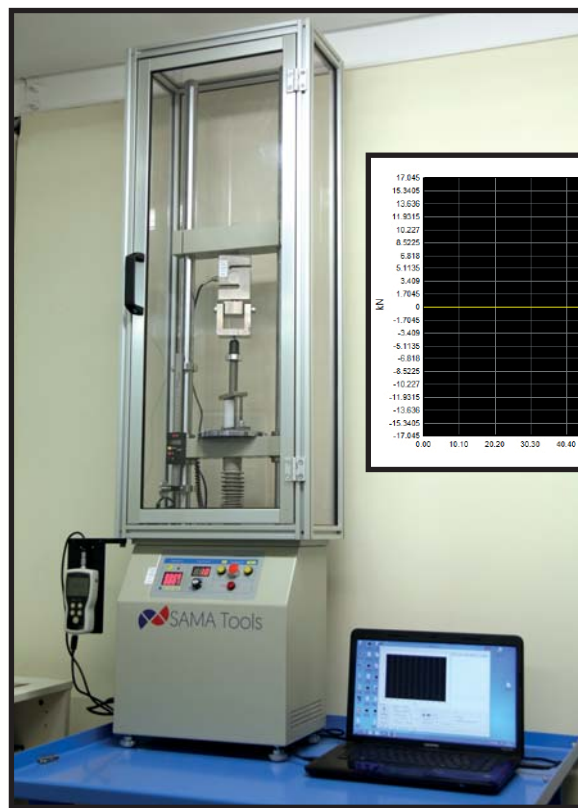

CONFEZIONAMENTO PERSONALIZZABILE
CUSTOMIZABLE PACKAGING
PERSONALISIERBARE VERPACKUNG
EMBALLAGE PERSONNALISABLE
EMBALAJE PERSONALIZABLE



ETICHETTA PERSONALIZZABILE
CUSTOMIZABLE LABEL
PERSONALISIERBARE ETIKETTEN
ETIQUETTE PERSONNALISABLE
ETIQUETA PERSONALIZABLE

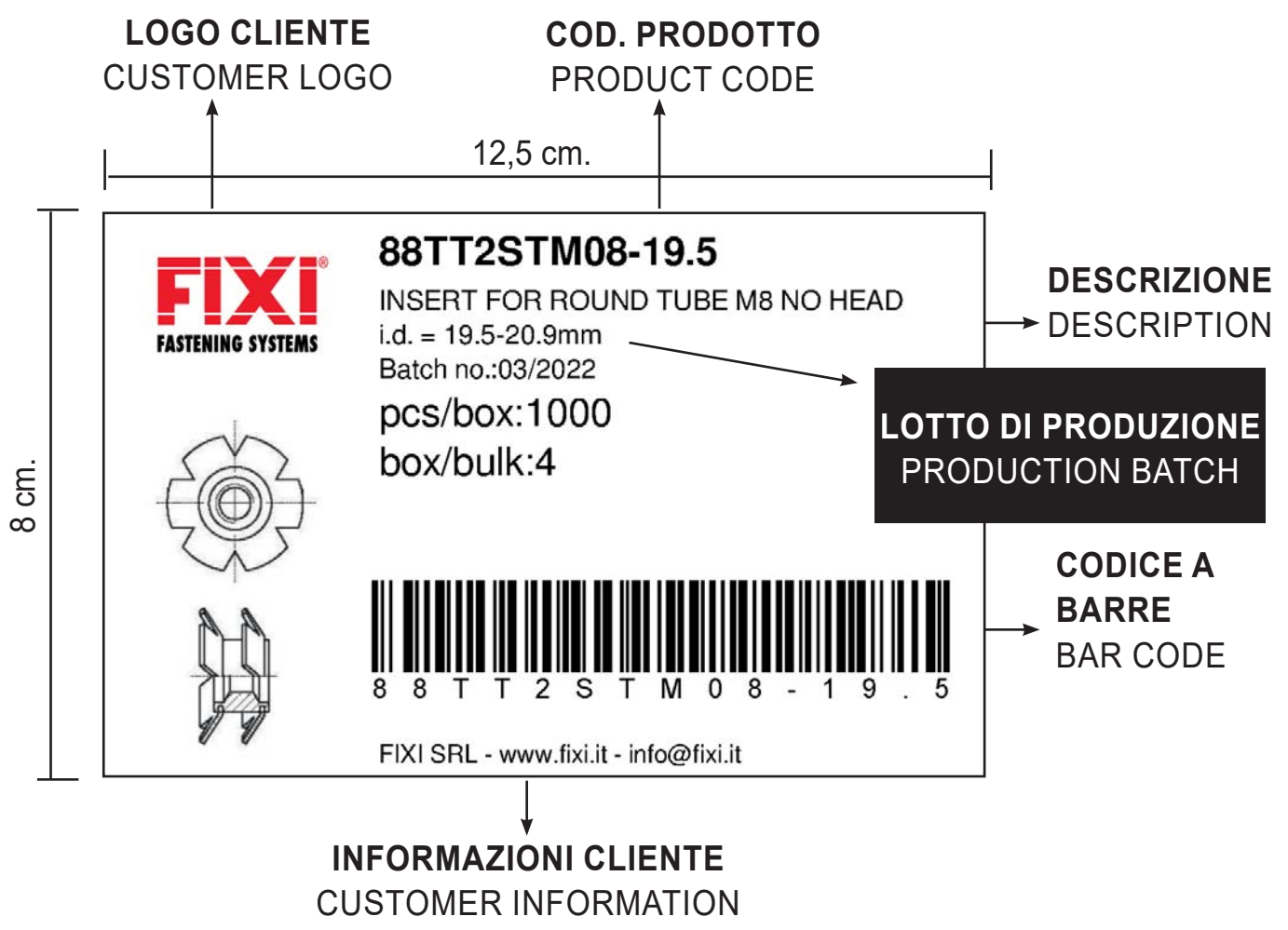

APPLICAZIONI E INSTALLAZIONE

APPLICATIONS AND INSTALLATION

ANWENDUNG UND INSTALLATION

APPLICATIONS ET INSTALLATION

APLICACIÓN E INSTALACIÓN

APPLICAZIONI ED INDUSTRIE

- *Arredamento: tavoli, sedie, lampade, letti, strutture dei divani, etc.*
- *Prodotti con strutture tubolari come attrezzi da palestra, carrelli, passeggini, rimorchi, etc.*
- *Strutture per insegne e strutture metalliche in generale.*

APPLICATIONS AND INDUSTRIES

- *Furniture: tables, chairs, lamps, beds, sofa frames, etc.*
- *Products with tubular structures such as gym equipment, trolleys, strollers, trailers, etc.*
- *Signage and metal structures in general.*

ANWENDUNGSBEREICHE UND INDUSTRIEGEBIETE

- *Innenausstattung/ Möbel: Tische, Stühle, Lampen, Betten, Sofa Gestelle usw.*
- *Produkte mit Rohr Strukturen wie Fitnessgeräte, Rollwagen, Kinderwagen, Anhänger usw.*
- *Gestelle für Werbeschilder und allgemein Metallstrukturen*

APPLICATIONS ET INDUSTRIES

- *Ameublement: tables, chaises, lampes, lits, structures de canapés, etc.*
- *Produits avec structures tubulaires tels que outils de gym, chariots, poussettes, remorques, etc.*
- *Structures pour enseignes et structures métalliques en général.*

APLICACIONES E INDUSTRIAS

- *Mobiliario: mesas, sillas, lámparas, camas, marcos de sofás, etc.*
- *Productos con estructuras tubulares, como equipo de gimnasio, carritos, porta-bebes, remolques, etc.*
- *Señalética, y estructuras metálicas en general.*

LINEE GUIDA PER L'INSTALLAZIONE

- *Un eventuale trattamento termico o superficiale dei tubi deve essere eseguito prima che vengano installati gli inserti.*
- *Gli inserti sono consigliati per tubi in acciaio temperato e alluminio. Non sono idonei per tubi in acciaio inox.*
- *Sebbene sia possibile installare gli inserti manualmente (ad esempio con un martello), è consigliabile utilizzare una pressa con il punzone della giusta misura.*

INSTALLATION GUIDE LINES

- *Any heat or surface treatment on the tubes must be carried out before installation.*
- *The inserts are recommended for aluminium and hardened steel tubes. They are not suitable for stainless steel tubes.*
- *Although it is possible to install the inserts manually (for example with a hammer), it is advisable to use a press with the right size punch.*

ANWENDUNGSRICHTLINIEN

- *Vor der Anwendung von den Gewindeeinsätzen, sollten die Rohre ggf. Wärme und Oberflächen behandelt werden.*
- *Die Gewindeeinsätze werden empfohlen für dein Einsatz bei Rohre aus getempertem Stahl oder aus Aluminium. Sind nicht geeignet für Edelstahl Rohre.*
- *Eine Handinstallation (z.B. mit einem Hammer) ist möglich aber empfohlen wird das einsetzen durch eine Presse mit einem Stempel der genauen Größe.*

GUIDE POUR L'INSTALLATION

- *Un éventuel traitement thermique ou superficiel des tubes doit être effectué avant l'installation de l'insert.*
- *Les inserts sont idéaux pour tubes en acier et en aluminium. Ils ne sont pas indiqués pour les tubes en inox.*
- *Bien qu'il soit possible d'installer les inserts manuellement (par exemple avec un marteau) il est conseillé d'utiliser une presse avec un moule de la bonne dimension.*

ISTRUCCIONES DE USO

- *Cualquier tratamiento superficial o de calor tiene que ser realizado antes de la instalación.*
- *Los insertos están recomendados para tubos de aluminio o acero endurecido. No son apropiados para tubos de acero inoxidable.*
- *A pesar de que es posible insertarlos manualmente (por ejemplo con un martillo), es recomendable utilizar una prensa con la fuerza apropiada.*

ESEMPI DI INSTALLAZIONE

EXAMPLES OF INSTALLATION

ANWENDUNGS BEISPIELE

EXEMPLES D'INSTALLATION

EJEMPLOS DE INSTALACIÓN

**INSERTI PER TUBI
TONDI SENZA TESTA**
INSERTS FOR ROUND
TUBES WITHOUT HEAD

**INSERTI PER TUBI
TONDI CON TESTA**
INSERTS FOR ROUND
TUBES WITH HEAD

**INSERTI PER TUBI
QUADRATI SENZA TESTA**
INSERTS FOR SQUARE
TUBES WITHOUT HEAD

**INSERTI PER TUBI
QUADRATI CON TESTA**
INSERTS FOR SQUARE
TUBES WITH HEAD

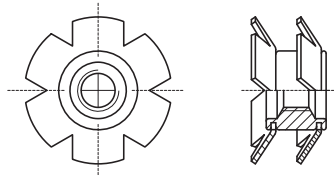
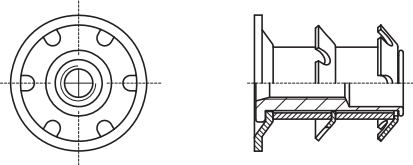
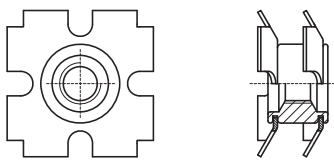
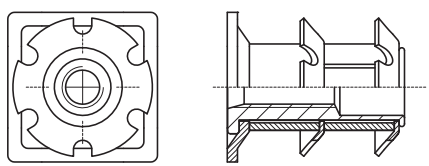
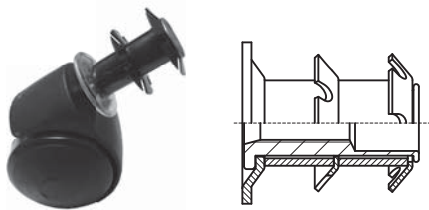

INDICE GENERALE
GENERAL INDEX
INHALTSVERZEICHNIS
SOMMAIRE GÉNÉRAL
INDICE GENERAL

	DESCRIZIONE - DESCRIPTION	PAGINA PAGE
	INSERTI PER TUBI TONDI SENZA TESTA <i>INSERTS FOR ROUND TUBES WITHOUT HEAD</i>	7 - 8
	INSERTI PER TUBI TONDI CON TESTA <i>INSERTS FOR ROUND TUBES WITH HEAD</i>	9 - 10
	INSERTI PER TUBI QUADRI SENZA TESTA <i>INSERTS FOR SQUARE TUBES WITHOUT HEAD</i>	11
	INSERTI PER TUBI QUADRI CON TESTA <i>INSERTS FOR SQUARE TUBES WITH HEAD</i>	12
	INSERTI PER TUBI TONDI CON ATTACCO RAPIDO PER PERNO <i>INSERTS FOR ROUND TUBES WITH SOCKET FOR STEM</i>	13

INSERTI PER TUBI TONDI SENZA TESTA

INSERTS FOR ROUND TUBES WITHOUT HEAD

GEWINDEEINSÄTZE FÜR RUNDE ROHRE OHNE BUND

INSERTS SANS TÊTE POUR TUBES RONDS

INSERTOS PARA TUBOS REDONDOS SIN CABEZA

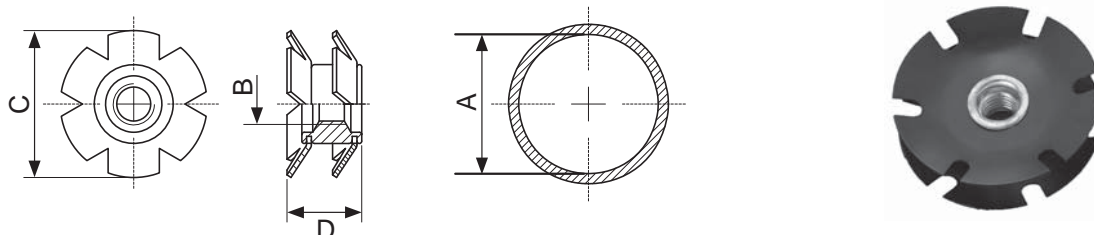

CODICE Code	A Ø Interno del Tubo Ø Tube internal range mm	B Misura Thread size	C* Dimensione Corone Crown diameter mm	D* Lunghezza Totale Total length mm
88TT2STM06-11.8	11.8-12.2	M6	13.0	10.0
88TT2STM06-12.6	12.6-13.2	M6	14.0	10.0
88TT2STM06-13.2	13.2-13.8	M6	14.5	10.0
88TT2STM06-13.8	13.8-14.2	M6	15.0	10.0
88TT2STM06-14.8	14.8-16.1	M6	16.6	10.0
88TT2STM08-14.8		M8	16.6	10.0
88TT2STM06-15.7	15.7-17.1	M6	17.5	10.0
88TT2STM08-15.7		M8	17.5	10.0
88TT2STM06-16.4	16.4-17.7	M6	18.2	10.0
88TT2STM08-16.4		M8	18.2	10.0
88TT2STM06-17.9	17.9-19.3	M6	20.0	10.0
88TT2STM08-17.9		M8	20.0	10.0
88TT2STM10-17.9		M10	20.0	10.0
88TT2STM06-18.9	18.9-20.2	M6	21.0	10.0
88TT2STM08-18.9		M8	21.0	10.0
88TT2STM10-18.9		M10	21.0	10.0
88TT2STM06-19.5	19.5-20.9	M6	21.5	10.0
88TT2STM08-19.5		M8	21.5	10.0
88TT2STM10-19.5		M10	21.5	10.0
88TT2STM06-20.9	20.9-21.4	M6	21.9	10.0
88TT2STM08-20.9		M8	21.9	10.0
88TT2STM10-20.9		M10	21.9	10.0
88TT2STM06-21.4	21.4-22.4	M6	23.0	10.0
88TT2STM08-21.4		M8	23.0	10.0
88TT2STM10-21.4		M10	23.0	10.0
88TT2STM06-22.1	22.1-23.4	M6	24.0	10.0
88TT2STM08-22.1		M8	24.0	10.0
88TT2STM10-22.1		M10	24.0	10.0
88TT2STM06-22.7	22.7-24.0	M6	24.5	10.0
88TT2STM08-22.7		M8	24.5	10.0
88TT2STM10-22.7		M10	24.5	10.0
88TT2STM06-24.6	24.6-25.6	M6	26.4	15.0
88TT2STM08-24.6		M8	26.4	15.0
88TT2STM10-24.6		M10	26.4	15.0
88TT2STM06-25.3	25.3-26.6	M6	27.6	15.0
88TT2STM08-25.3		M8	27.6	15.0
88TT2STM10-25.3		M10	27.6	15.0
88TT2STM06-26.0	26.0-28.0	M6	28.8	15.0
88TT2STM08-26.0		M8	28.8	15.0
88TT2STM10-26.0		M10	28.8	15.0

* Dimensioni non vincolanti / * Not binding dimensions

INSERTI PER TUBI TONDI SENZA TESTA

INSERTS FOR ROUND TUBES WITHOUT HEAD
 GEWINDEINSÄTZE FÜR RUNDE ROHRE OHNE BUND
 INSERTS SANS TÊTE POUR TUBES RONDS
 INSERTOS PARA TUBOS REDONDOS SIN CABEZA

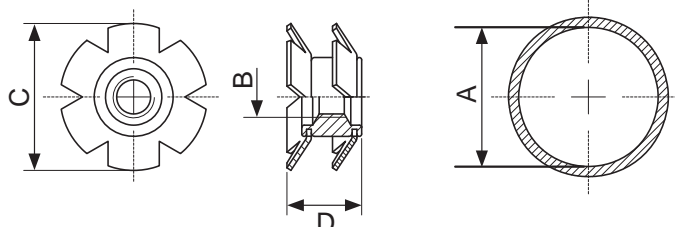

CODICE Code	A Ø Interno del Tubo Ø Tube internal range mm	B Misura Thread size	C* Dimensione Corone Crown diameter mm	D* Lunghezza Totale Total length mm
88TT2STM06-28.4	28.4-29.8	M6	30.6	15.0
88TT2STM08-28.4		M8	30.6	15.0
88TT2STM10-28.4		M10	30.6	15.0
88TT2STM06-29.8	29.8-30.8	M6	31.8	15.0
88TT2STM08-29.8		M8	31.8	15.0
88TT2STM06-31.7	31.7-32.9	M6	33.8	15.0
88TT2STM08-31.7		M8	33.8	15.0
88TT2STM10-31.7		M10	33.8	15.0
88TT2STM06-32.7	32.7-33.9	M6	35.0	15.0
88TT2STM08-32.7		M8	35.0	15.0
88TT2STM10-32.7		M10	35.0	15.0
88TT2STM06-33.7	33.7-35.0	M6	36.0	15.0
88TT2STM08-33.7		M8	36.0	15.0
88TT2STM10-33.7		M10	36.0	15.0
88TT2STM06-34.8	34.8-36.1	M6	37.1	15.0
88TT2STM08-34.8		M8	37.1	15.0
88TT2STM10-34.8		M10	37.1	15.0
88TT2STM06-36.0	36.0-38.0	M6	39.0	15.0
88TT2STM08-36.0		M8	39.0	15.0
88TT2STM10-36.0		M10	39.0	15.0
88TT2STM06-37.3	37.3-39.3	M6	40.0	15.0
88TT2STM08-37.3		M8	40.0	15.0
88TT2STM10-37.3		M10	40.0	15.0
88TT2STM06-38.4	38.4-40.4	M6	41.3	15.0
88TT2STM08-38.4		M8	41.3	15.0
88TT2STM10-38.4		M10	41.3	15.0
88TT2STM06-41.4	41.4-42.4	M6	43.5	15.0
88TT2STM08-41.4		M8	43.5	15.0
88TT2STM10-41.4		M10	43.5	15.0
88TT2STM06-42.2	42.2-44.2	M6	45.2	15.0
88TT2STM08-42.2		M8	45.2	15.0
88TT2STM10-42.2		M10	45.2	15.0
88TT2STM06-44.6	44.6-46.8	M6	47.6	15.0
88TT2STM08-44.6		M8	47.6	15.0
88TT2STM10-44.6		M10	47.6	15.0
88TT2STM06-47.5	47.5-48.8	M6	50.0	15.0
88TT2STM08-47.5		M8	50.0	15.0
88TT2STM10-47.5		M10	50.0	15.0

* Dimensioni non vincolanti / * Not binding dimensions

INSERTI PER TUBI TONDI CON TESTA

INSERTS FOR ROUND TUBES WITH HEAD

GEWINDEEINSÄTZE FÜR RUNDE ROHRE MIT BUND

INSERTS AVEC TÊTE POUR TUBES RONDS

INSERTOS PARA TUBOS REDONDOS CON CABEZA

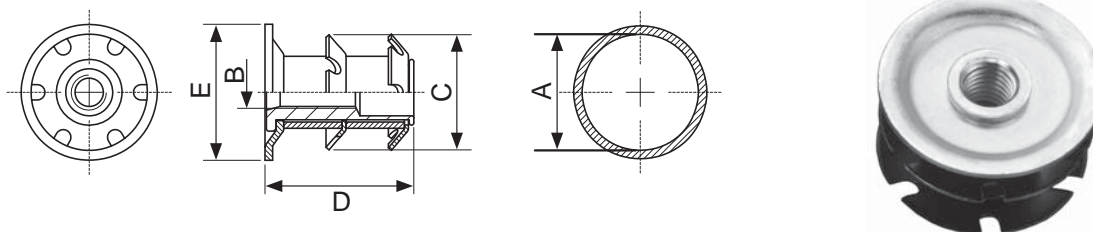

CODICE Code	A Ø Interno del Tubo Ø Tube internal range mm	B Misura Thread size	C* Dimensione Corone Crown diameter mm	D* Lunghezza Totale Total length mm	E Ø Testa Ø Head mm
88TT2CTM08-14.8	14.8-16.1	M8	16.6	22.0	19.0
88TT2CTM08-15.7	15.7-17.1	M8	18.1	22.0	19.0
88TT2CTM08-16.4	16.4-17.7	M8	18.2	22.0	19.0
88TT2CTM08-17.9	17.9-19.3	M8	20.0	22.0	22.2
88TT2CTM10-17.9		M10	20.0	22.0	
88TT2CTM08-18.9	18.9-20.2	M8	21.0	22.0	22.2
88TT2CTM10-18.9		M10	21.0	22.0	
88TT2CTM08-19.2	19.2-21.0	M8	22.0	22.0	25.4
88TT2CTM10-19.2		M10	22.0	22.0	
88TT2CTM08-21.4	21.4-22.4	M8	23.0	22.0	25.4
88TT2CTM10-21.4		M10	23.0	22.0	
88TT2CTM08-22.1	22.1-23.4	M8	24.7	22.0	25.4
88TT2CTM10-22.1		M10	24.7	22.0	
88TT2CTM08-22.7	22.7-24.0	M8	24.5	22.0	25.4
88TT2CTM10-22.7		M10	24.5	22.0	
88TT2CTM08-24.6	24.6-25.6	M8	26.4	22.0	28.5
88TT2CTM10-24.6		M10	26.4	22.0	
88TT2CTM08-25.3	25.3-26.6	M8	27.6	22.0	28.5
88TT2CTM10-25.3		M10	27.6	22.0	
88TT2CTM08-26.6	26.6-27.6	M8	28.2	22.0	28.5
88TT2CTM10-26.6		M10	28.2	22.0	
88TT2CTM08-26.0	26.0-28.0	M8	28.4	22.0	30.0
88TT2CTM10-26.0		M10	28.4	22.0	
88TT2CTM08-28.4	28.4-29.8	M8	31.0	22.0	31.8
88TT2CTM10-28.4		M10	31.0	22.0	
88TT2CTM08-29.8	29.8-30.8	M8	31.8	22.0	31.8
88TT2CTM10-29.8		M10	31.8	22.0	
88TT2CTM08-31.7	31.7-32.9	M8	33.7	22.0	35.0
88TT2CTM10-31.7		M10	33.7	22.0	
88TT2CTM08-32.7	32.7-33.9	M8	35.0	22.0	38.0
88TT2CTM10-32.7		M10	35.0	22.0	

* Dimensioni non vincolanti / * Not binding dimensions

INSERTI PER TUBI TONDI CON TESTA

INSERTS FOR ROUND TUBES WITH HEAD
 GEWINDEEINSÄTZE FÜR RUNDE ROHRE MIT BUND
 INSERTS AVEC TÊTE POUR TUBES RONDS
 INSERTOS PARA TUBOS REDONDOS CON CABEZA

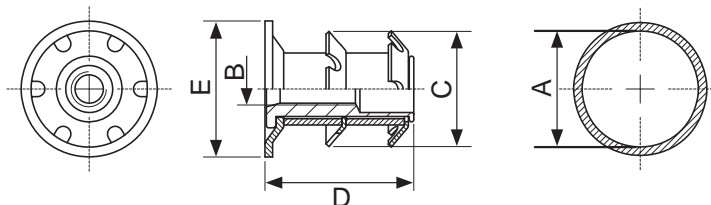

CODICE Code	A Ø Interno del Tubo Ø Tube internal range mm	B Misura Thread size	C* Dimensione Corone Crown diameter mm	D* Lunghezza Totale Total length mm	E Ø Testa Ø Head mm
88TT2CTM08-33.7	33.7-35.0	M8	36.0	22.0	38.0
88TT2CTM10-33.7		M10	36.0	22.0	
88TT2CTM08-34.8	34.8-36.1	M8	37.1	22.0	38.0
88TT2CTM10-34.8		M10	37.1	22.0	
88TT2CTM08-36.0	36.0-38.0	M8	39.0	22.0	40.0
88TT2CTM10-36.0		M10	39.0	22.0	
88TT2CTM08-37.3	37.3-39.3	M8	40.0	22.0	41.3
88TT2CTM10-37.3		M10	40.0	22.0	
88TT2CTM08-38.4	38.4-40.4	M8	41.3	22.0	44.5
88TT2CTM10-38.4		M10	41.3	22.0	
88TT2CTM08-41.4	41.4-42.4	M8	43.5	22.0	44.5
88TT2CTM10-41.4		M10	43.5	22.0	
88TT2CTM08-43.7	43.7-45.7	M8	46.7	22.0	47.6
88TT2CTM10-43.7		M10	46.7	22.0	
88TT2CTM08-42.2	42.2-44.2	M8	45.2	22.0	50.8
88TT2CTM10-42.2		M10	45.2	22.0	
88TT2CTM08-43.7	43.7-45.7	M8	46.7	22.0	50.8
88TT2CTM10-43.7		M10	46.7	22.0	
88TT2CTM08-44.6	44.6-46.8	M8	47.6	22.0	50.8
88TT2CTM10-44.6		M10	47.6	22.0	
88TT2CTM08-46.8	46.8-47.8	M8	49.0	22.0	50.8
88TT2CTM10-46.8		M10	49.0	22.0	
88TT2CTM08-47.5	47.5-48.8	M8	50.0	22.0	50.8
88TT2CTM10-47.5		M10	50.0	22.0	
88TT2CTM08-53.0	53.0-55.0	M8	56.0	22.0	57.1
88TT2CTM10-53.0		M10	56.0	22.0	
88TT2CTM08-56.0	56.0-58.0	M8	59.0	22.0	60.0
88TT2CTM10-56.0		M10	59.0	22.0	
88TT2CTM08-59.5	59.5-61.5	M8	62.5	22.0	63.5
88TT2CTM10-59.5		M10	62.5	22.0	

* Dimensioni non vincolanti / * Not binding dimensions

INSERTI PER TUBI QUADRI SENZA TESTA

INSERTS FOR SQUARE TUBES WITHOUT HEAD

GEWINDEEINSÄTZE FÜR QUADRATISCHE ROHRE OHNE BUND

INSERTS SANS TÊTE POUR TUBES CARRÉS

INSERTOS PARA TUBOS CUADRADOS SIN CABEZA

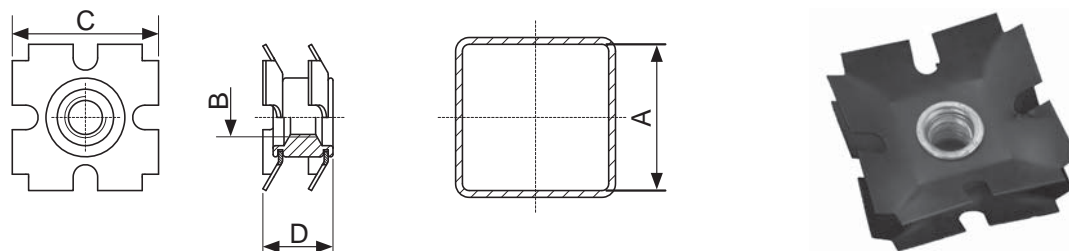

CODICE Code	A Ø Interno del Tubo Ø Tube internal range mm	B MISURA Thread size	C* Dimensione Corone Crown diameter mm	D* Lunghezza Totale Total length mm
88TQ2STM06-15.7	15.7-17.1	M6	17.5	10.0
88TQ2STM06-16.7	16.7-18.1	M6	19.0	10.0
88TQ2STM08-16.7		M8	19.0	10.0
88TQ2STM06-18.9	18.9-20.2	M6	21.0	10.0
88TQ2STM08-18.9		M8	21.0	10.0
88TQ2STM06-22.1	22.1-23.4	M6	24.0	10.0
88TQ2STM08-22.1		M8	24.0	10.0
88TQ2STM06-26.0	26.0-28.0	M6	28.8	15.0
88TQ2STM08-26.0		M8	28.8	15.0
88TQ2STM06-28.4	28.4-29.8	M6	30.6	15.0
88TQ2STM08-28.4		M8	30.6	15.0
88TQ2STM06-34.8	34.8-36.1	M6	37.5	15.0
88TQ2STM08-34.8		M8	37.5	15.0
88TQ2STM06-47.5	47.5-48.8	M6	50.0	15.0
88TQ2STM08-47.5		M8	50.0	15.0
88TQ2STM10-47.5		M10	50.0	15.0

* Dimensioni non vincolanti / * Not binding dimensions

INSERTI PER TUBI QUADRI CON TESTA

INSERTS FOR SQUARE TUBES WITH HEAD

GEWINDEEINSÄTZE FÜR QUADRATISCHE ROHRE MIT BUND

INSERTS AVEC TÊTE POUR TUBES CARRÉS

INSERTOS PARA TUBOS CUADRADOS CON CABEZA

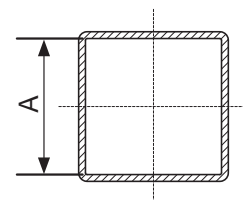
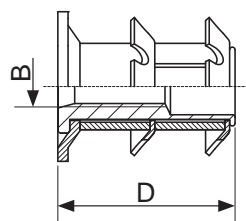
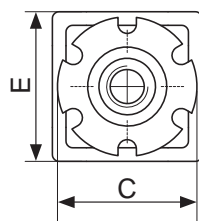

CODICE Code	A Ø Interno del Tubo Ø Tube internal range mm	B Misura Thread size	C* Dimensione Corone Crown diameter mm	D* Lunghezza Totale Total length mm	E Testa Head mm
88TQ2CTM08-15.7	15.7-17.1	M8	18.1	22.0	19x19
88TQ2CTM08-18.9	18.9-20.2	M8	21.0	22.0	22x22
88TQ2CTM10-18.9		M10	21.0	22.0	
88TQ2CTM08-22.1	22.1-23.4	M8	24.7	22.0	25x25
88TQ2CTM10-22.1		M10	24.7	22.0	
88TQ2CTM08-25.3	25.3-26.6	M8	27.5	22.0	28x28
88TQ2CTM10-25.3		M10	27.5	22.0	
88TQ2CTM08-26.4	26.4-27.8	M8	29.1	22.0	30x30
88TQ2CTM10-26.4		M10	29.1	22.0	
88TQ2CTM08-28.4	28.4-29.8	M8	30.7	22.0	32x32
88TQ2CTM10-28.4		M10	30.7	22.0	
88TQ2CTM08-34.8	34.8-36.1	M8	37.1	22.0	38x38
88TQ2CTM10-34.8		M10	37.1	22.0	
88TQ2CTM08-36.0	36.0-38.0	M8	39.0	22.0	40x40
88TQ2CTM10-36.0		M10	39.0	22.0	
88TQ2CTM08-41.4	41.4-42.4	M8	44.0	22.0	45x45
88TQ2CTM10-41.4		M10	44.0	22.0	
88TQ2CTM08-47.5	47.5-48.8	M8	49.5	22.0	50x50
88TQ2CTM10-47.5		M10	49.5	22.0	

* Dimensioni non vincolanti / * Not binding dimensions

INSERTI PER TUBI TONDI CON ATTACCO RAPIDO PER PERNO

INSERTS FOR ROUND TUBES WITH SOCKET FOR STEM

GEWINDEEINSÄTZE FÜR RUNDE ROHRE MIT BOLZEN SCHNELLVERSCHLUSS

INSERTS POUR TUBES RONDS AVEC BRANCHEMENT RAPIDE POUR TIGE

INSERTOS PARA TUBOS REDONDOS CON FIJACIÓN RÁPIDA PARA PERNO

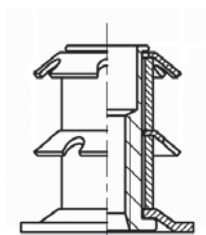

CODICE Code	Ø Interno del Tubo Ø Tube internal range mm	Ø Foro / Perno Ø Hole / Stem	Ø Testa Ø Head mm
88TT2CTD11-22.1	22.1-23.4	11 mm	25.4
88TT2CTD11-25.3	25.3-26.6	11 mm	28.6
88TT2CTD11-28.4	28.4-29.8	11 mm	31.7

* Dimensioni non vincolanti / * Not binding dimensions

NOTE
REMARKS
BEMERKUNGEN
REMARQUES
OBSERVACIONES



* Dimensioni non vincolanti / * Not binding dimensions

Fissaggi per lamiera - *Fasteners for sheet metal*

RIVETTI A STRAPPO - *BLIND RIVETS*



INSERTI FILETTATI - *THREADED INSERTS*



AUTOFISSANTI - *SELF CLINCHING FASTENERS*



WELDING STUDS - *PERNI A SALDARE*



Fissaggi per corpi pieni *Fasteners for solid parts*

BUSSOLE AUTOFILETTANTI, SPECIALI E FILETTI RIPORTATI *SELF-TAPPING, SPECIAL AND WIRE INSERTS*



Fissaggi per la plastica *Fasteners for plastics*

INSERTI IN OTTONE - *BRASS INSERTS*



Fissaggi per tubi - *Fasteners for tubes*



Fissaggi per marmo, pietra e compositi - *Fasteners for marble, stone and composites*





RIVETTI A STRAPPO
BLIND RIVETS



INSERTI FILETTATI
THREADED INSERTS



AUTOFISSANTI
*SELF-CLINCHING
FASTENERS*



PERNI A SALDARE
WELDING STUDS



**FISSAGGI PER MATERIE
PLASTICHE**
FASTENERS FOR PLASTICS



FILETTI RIPORTATI
WIRE INSERTS



INSERTI PER TUBI
INSERTS FOR TUBES



**BUSSOLE AUTOFILETTANTI
E SPECIALI**
*SELF-TAPPING AND SPECIAL
THREADED INSERTS*



**INSERTI PER PIETRE
E SUPERFICI SOLIDE**
*INSERTS FOR STONES
AND SOLID SURFACES*

FIXI®

FASTENING SYSTEMS

Via Bellardi, 40/A - 10146 Torino (Italy)
Tel. 0039 011.7072398 / 7070877 - Fax 0039 011.7072521
E-mail: info@fixi.it - www.fixi.it

FIXI® VALLE D'AOSTA - PIEMONTE

LOMBARDIA - LIGURIA

Via Valgioie, 94 - 10146 Torino Italy
Tel. 0039 011.0882009 - Fax 0039 011.0882012
E-mail: info@fixivpl.it - www.fixi.it

FIXI® 3v

TRENTINO - VENETO - FRIULI

Via Keplero, 4G/H - Z.I. di Tognana - 35028 Piove di Sacco (PD) Italy
Tel. 0039 049.8079285 - Fax 0039 049.8087725
E-mail: trevenezie@fixitrevenezie.it - www.fixi.it

FIXI® ets

EMILIA ROMAGNA - TOSCANA - SARDEGNA

Via delle Querce, 22 - 40011 Anzola dell'Emilia (BO) Italy
Tel. 0039 051.0353243 - Fax 0039 051.0353244
E-mail: info@fixiets.it - www.fixi.it

FIXI® u.a

**MARCHE - ABRUZZO - UMBRIA - MOLISE
BASILICATA - SICILIA - CALABRIA - PUGLIA**

Via Roma, 10 - 63078 Pagliare del Tronto fraz. di Spinetoli (AP) Italy
Tel. 0039 0736.814110 - Fax 0039 0736.984002
E-mail: info@fixiua.it - www.fixi.it

FIXI® cs:

LAZIO - CAMPANIA

Via Fonte Monsignore snc - 64010 Ancarano (TE) Italy
Tel. 0039 0861.739878 - E-mail: info@fixicentrosud.it - www.fixi.it

