

ATTREZZATURE A BATTERIA BATTERY POWERED TOOLS



02RBZ

02RBZPLUS

90TBZ

FIXI®



SISTEMI DI FISSAGGIO
FASTENING SYSTEMS

RIVETTATRICI A BATTERIA

BATTERY POWERED RIVETERS

Due modelli molto veloci e completi di raccogliitore per mandrini nella parte posteriore. Due batterie incluse. Valigette antiurto con accessori. Marchiatura CE secondo lo standard EU Nr. 2006/42/EC.

Two high speed models, equipped with mandrel collector. Two batteries included. Shockproof case complete with accessories. CE marking according to the EU standard n. 2006/42/EC.

		
	02RBZ	02RBZPLUS
Dimensioni / Dimensions	270x280	270x280
Dimensione rivetti / Rivet capacity	ø 2.4-5.0 mm	ø 4-6.4 mm
Corsa / Stroke	22 mm.	26 mm.
Motore / Drive	18V DC	18V DC
Forza di installazione / Setting force	10.000 N	20.000 N
Capacità batteria / Battery	2.0 Ah	2.0 Ah
Durata della batteria / Long lasting battery	750 pezzi / pcs. (inox Ø 5 mm)	500 pezzi / pcs. (inox Ø 6.4 mm)
Peso con batteria / Weight including battery	1.85 Kg	1.9 Kg
Rumorosità / Noise level	78.8 dB	78.8 dB
Vibrazioni / Vibration	< 2.5 m/s ²	< 2.5 m/s ²
Tempo di caricamento batteria / Battery Charging Time	<80 min.	<80 min.

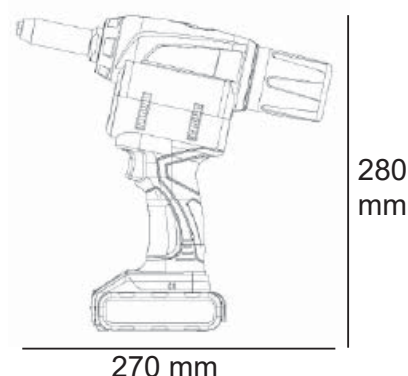

Disponibile anche la versione oleopneumatica. / Oleopneumatic version also available.

TIRAINSERTI A BATTERIA

BATTERY POWERED TOOL FOR THREADED INSERTS

Modello molto veloce. Due batterie incluse. Valigetta antiurto con accessori.
 Marcatura CE ai sensi della Direttiva 2006/42/CE.

High speed model. Two batteries included. Shockproof case complete with accessories. CE marking according to the EU standard n. 2006/42/EC.

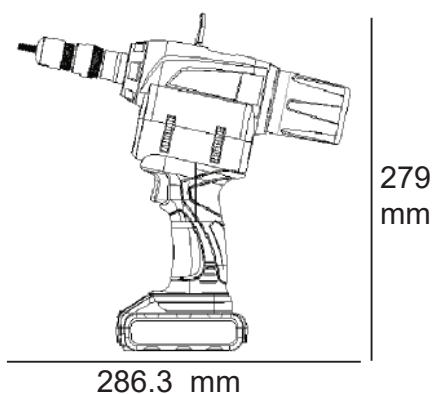

	
	90TBZ
Dimensioni /Dimensions	286.3x279
Dimensioni inserti / Rivet Nuts capacity	M4-M8 (in tutti i materiali/in all materials) M10 (Allu-Acc. / Alu-Steel)
Corsa / Stroke	6 mm.
Motore / Drive	18V DC
Forza di installazione / Setting force	16.000 N
Capacità batteria / Battery	2.0 Ah
Durata della batteria / Long lasting battery	600 inserti cilindrici M6 acciaio/round steel nuts (500 M10 acciaio/steel)
Peso con batteria / Weight including battery	2.15 Kg
Rumorosità / Noise level	76.5 dB
Vibrazioni / Vibration	< 2.5 m/s ²
Tempo di caricamento batteria / Battery Charging Time	<80 min.



Disponibile anche la versione oleopneumatica. / Oleopneumatic version also available.



RIVETTI A STRAPPO
BLIND RIVETS



INSERTI FILETTATI
THREADED INSERTS



AUTOFISSANTI
*SELF-CLINCHING
FASTENERS*



PERNI A SALDARE
WELDING STUDS



**FISSAGGI PER MATERIE
PLASTICHE**
FASTENERS FOR PLASTICS

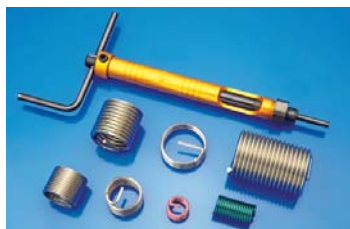

FILETTI RIPORTATI
WIRE INSERTS



INSERTI PER TUBI
INSERTS FOR TUBES

FIXI®

Member of CISO Federation



SEDE CENTRALE - HEADQUARTER

Via Bellardi, 40/A - 10146 Torino (Italy)

Tel. 0039 011.7072398 / 7070877 - Fax 0039 011.7072521

E-mail: info@fixi.it - www.fixi.it

FIXI[®] **vpl**

VALLE D'AOSTA - PIEMONTE - LIGURIA

Via Valgioie, 94 - 10146 Torino Italy

Tel. 0039 011.0882009 - Fax 0039 011.0882012

E-mail: info@fixivpl.it - www.fixi.it

FIXI[®] **fl**

LOMBARDIA - CANTON TICINO

Via Delle Gallarane, 10/12 - 22046 Merone (CO) Italy

Tel. 0039 031.3333486 - Fax 0039 031.3339064

E-mail: info@fixilombardia.it - www.fixi.it

FIXI[®] **3v**

TRENTINO - VENETO - FRIULI

Via Keplero, 4G/H - Z.I. di Tognana - 35028 Piove di Sacco (PD) Italy

Tel. 0039 049.8079285 - Fax 0039 049.8087725

E-mail: trevenezie@fixitrevenezie.it - www.fixi.it

FIXI[®] **ets**

EMILIA ROMAGNA - TOSCANA - SARDEGNA

Via Secci, 4 - 40132 Bologna Italy

Tel. 0039 051.0353243 - Fax 0039 051.0353244

E-mail: amministrazione@fixiets.it - www.fixi.it

FIXI[®] **u.a**

MARCHE - UMBRIA - ABRUZZO - MOLISE

Via Roma, 10 - 63078 Fr. Pagliare del Tronto Spinetoli (AP) Italy

Tel. 0039 0736.814110 - Fax 0039 0736.984002

E-mail: info@fixiua.it - www.fixi.it

FIXI[®] **csi**

CENTRO SUD ITALIA

Via Arno, 50 - 63082 Castel di Lama (AP) (ITALY)

Tel. 0039 0736.812922 - Fax 0039 0736.812922

E-mail: info@fixicentrosud.it - www.fixi.it