

1

46.52

# RIVETTATRICI OLEOPNEUMATICHE PER RIVETTI A STRAPPO

OLEOPNEUMATIC TOOLS FOR BLIND RIVETS

OLEO PNEUMATISCHE BLINDNIETE WERKZUEGE

OUTILS OLEOPNEUMATIQUES POUR RIVETS AVEUGLES

HERRAMIENTA OLEONEUMÁTICAS PARA REMACHES CLAVO

## 02F2

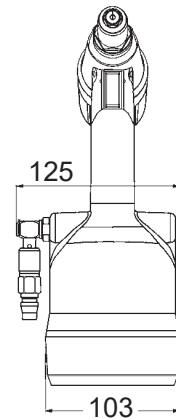
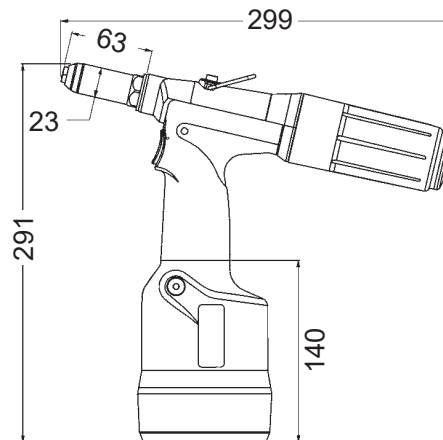

CODICE CODE	CARATTERISTICHE TECHNICAL FEATURES				UTILIZZO CAPACITY				
	PRESSIONE DI UTILIZZO PRESSURE REQUIRED	PESO WEIGHT	CORSA STROKE	FORZA TRACTION POWER	RIVETTO Ø	ALLUMINIO / ACCIAIO ALUMINIUM/STEEL	ACCIAIO / ACCIAIO STEEL/STEEL	RAME / ACCIAIO COPPER/STEEL	INOX / INOX STAINLESS STEEL/ STAINLESS STEEL
02F2	5 - 7 BAR	1,3 Kg	20 mm	10 KN	3,2 mm	●	●	●	●
					4 mm	●	●	●	●
					4,8 - 5 mm	●	●	●	●
					6 mm	●			
					6,4 mm	●			

CODICE CODE	PRODOTTO PRODUCT	CARATTERISTICHE TECHNICAL FEATURES
02CLAMPJAWSF2/F3	MORSETTI DI RICAMBIO SPARE CLAMPING JAWS	No. 1 Set (3 Pcs)
02U32F2	UGELLI DI RICAMBIO SPARE NOSEPIECES	Diam. 3,2 mm
02U40F2/F3	UGELLI DI RICAMBIO SPARE NOSEPIECES	Diam. 4,0 mm
02U48F2/F3	UGELLI DI RICAMBIO SPARE NOSEPIECES	Diam. 4,8 - 5 mm
02U64F2/F3	UGELLI DI RICAMBIO SPARE NOSEPIECES	Diam. 6,4 mm

Morsetto  
Clamping Jaw



Ugello  
Nosepiece



Ugelli e teste prolungate a pag. 49  
Longer nosepieces and extended head at page 49

# RIVETTATRICI OLEOPNEUMATICHE PER RIVETTI A STRAPPO

OLEOPNEUMATIC TOOLS FOR BLIND RIVETS

OLEO PNEUMATISCHE BLINDNIETE WERKZUEGE

OUTILS OLEOPNEUMATIQUES POUR RIVETS AVEUGLES

HERRAMIENTA OLEONEUMÁTICAS PARA REMACHES CLAVO

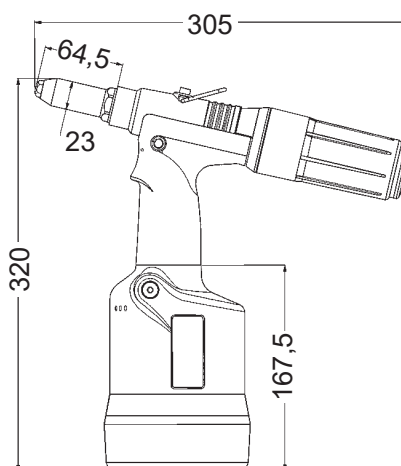

## O2F3

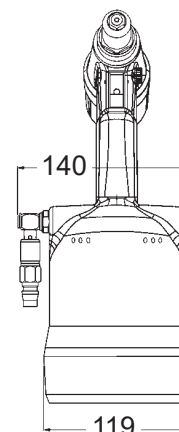

DA UTILIZZARE CON I RIVETTI STRUTTURALI MFX  
 SUITABLE FOR MFX SERIES STRUCTURAL RIVETS  
 ZUR VERARBEITUNG VON STRUKTURELLEN MFX BLINDNIETE  
 À UTILISER AVEC LES RIVETS DE STRUCTURE MFX  
 PARA UTILIZAR CON REMACHES CLAVO ESTRUCTURALES MFX

CODICE CODE	CARATTERISTICHE TECHNICAL FEATURES				UTILIZZO CAPACITY				
	PRESSIONE DI UTILIZZO PRESSURE REQUIRED	PESO WEIGHT	CORSA STROKE	FORZA TRACTION POWER	RIVETTO Ø	ALLUMINIO / ACCIAIO ALUMINIUM/STEEL	ACCIAIO / ACCIAIO STEEL/STEEL	RAME / ACCIAIO COPPER/STEEL	INOX / INOX STAINLESS STEEL/ STAINLESS STEEL
O2F3	5 - 7 BAR	1,6 Kg	26,7 mm	15.2 KN	4 mm	●	●	●	●
					4,8 - 5 mm	●	●	●	●
					6.0 mm	●	●	●	●
					6.4 mm	●	●	●	●
					STRUTTURALI MFX STRUCTURAL RIVETS MFX	●	●		●

CODICE CODE	PRODOTTO PRODUCT	CARATTERISTICHE TECHNICAL FEATURES
O2CLAMPJAWSF2/F3	MORSETTI DI RICAMBIO SPARE CLAMPING JAWS	No. 1 Set (3 Pcs)
O2U40F2/F3	UGELLI DI RICAMBIO SPARE NOSEPIECES	Diam. 4,0 mm
O2U48F2/F3	UGELLI DI RICAMBIO SPARE NOSEPIECES	Diam. 4,8 - 5 mm
O2U64F2/F3	UGELLI DI RICAMBIO SPARE NOSEPIECES	Diam. 6,4 mm
O2U48F3M	UGELLI DI RICAMBIO per MONOFIX SPARE NOSEPIECES for MONOFIX	Diam. 4,8 mm
O2U64F3M	UGELLI DI RICAMBIO per MONOFIX SPARE NOSEPIECES for MONOFIX	Diam. 6,4 mm

Morsetto  
Clamping Jaw



Ugello  
Nosepiece



Ugelli e teste prolungate a pag. 49  
 Longer nosepieces and extended head at page 49

# RIVETTATRICI OLEOPNEUMATICHE PER RIVETTI A STRAPPO

OLEOPNEUMATIC TOOLS FOR BLIND RIVETS

OLEO PNEUMATISCHE BLINDNIETE WERKZUEGE

OUTILS OLEOPNEUMATIQUES POUR RIVETS AVEUGLES

HERRAMIENTA OLEONEUMÁTICAS PARA REMACHES CLAVO

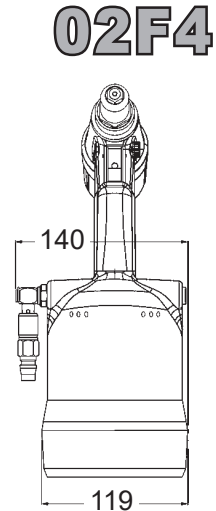
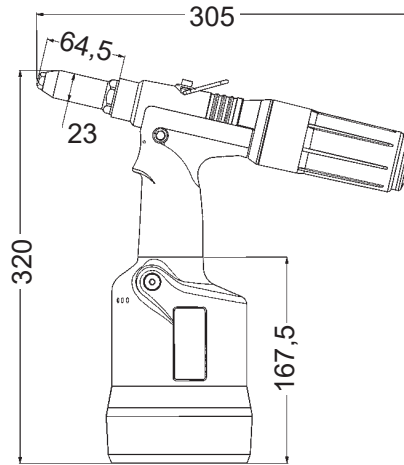

## 02F4

DA UTILIZZARE CON I RIVETTI STRUTTURALI MBX  
 SUITABLE FOR MBX SERIES STRUCTURAL RIVETS  
 ZUR VERARBEITUNG VON STRUKTURELLEN MBX BLINDNIETE  
 À UTILISER AVEC LES RIVETS DE STRUCTURE MBX  
 PARA UTILIZAR CON REMACHES CLAVO ESTRUCTURALES MBX

CODICE CODE	CARATTERISTICHE TECHNICAL FEATURES				UTILIZZO CAPACITY				
	PRESSIONE DI UTILIZZO PRESSURE REQUIRED	PESO WEIGHT	CORSA STROKE	FORZA TRACTION POWER	RIVETTO Ø	ALLUMINIO / ACCIAIO ALUMINIUM/STEEL	ACCIAIO / ACCIAIO STEEL/STEEL	RAME / ACCIAIO COPPER/STEEL	INOX / INOX STAINLESS STEEL/ STAINLESS STEEL
02F4	5 - 7 BAR	1,6 Kg	19 mm	18 KN	4,8 - 5 mm	●	●	●	●
					6.0 mm	●	●	●	●
					6.4 mm	●	●	●	●
					STRUTTURALI MBX MBX STRUCTURAL RIVETS	●	●		●

CODICE CODE	PRODOTTO PRODUCT	CARATTERISTICHE TECHNICAL FEATURES
02CLAMPJAWSF4	MORSETTI DI RICAMBIO SPARE CLAMPING JAWS	No. 1 Set (3 Pcs)
02U48F2/F3/F4	UGELLI DI RICAMBIO SPARE NOSEPIECES	Diam. 4,8 - 5 mm
02U60F2/F3/F4	UGELLI DI RICAMBIO SPARE NOSEPIECES	Diam. 6,0 mm
02U64F2/F3/F4	UGELLI DI RICAMBIO SPARE NOSEPIECES	Diam. 6,4 mm

Morsetto  
Clamping Jaw



Ugello  
Nosepiece



Ugelli e teste prolungate a pag. 49  
 Longer nosepieces and extended head at page 49

## UGELLI E TESTE PROLUNGATE PER RIVETTATRICI F1/F2/F3/F4

LONGER NOSEPIECES AND EXTENDED HEADS FOR OLEPNEUMATIC TOOLS F1/F2/F3/F4

VERLÄNGERTE MUNDSTÜCKE UND KÖPFE FÜR DIE OLEO-PNEUMATISCHE GERÄTE F1/F2/F3/F4

BUSES ET TÊTES RALLONGÉES POUR OUTILS À RIVETER F1/F2/F3/F4

BOQUILLAS Y CABEZALES PROLONGADOS PARA LAS REMACHADORAS F1/F2/F3/F4

SE SI UTILIZZANO UGELLI PROLUNGATI IL MANDRINO DEVE USCIRE DALL'UGELLO ALMENO DI 12 MM

WHEN USING LONGER NOSEPIECES MANDREL LENGTH MUST PROTRUDE AT LEAST 12 MM

WENN VERLÄNGERTE MUNDSTÜCKE VERWENDET WERDEN, MUß DER DORN MIN 12 MM HERAUSRAGEN

DANS LE CAS D'UTILISATION DE BUSES RALLONGÉES, LE MANDRIN DOIT SORTIR DE LA BUSE D'AU MOINS 12 MM

SI SE USAN BOQUILLAS PROLONGADAS EL MANDRIL DEBE SOBRESALIR DE LA BOQUILLA AL MENOS 12 MM

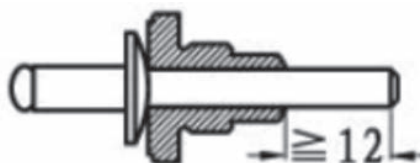

### UGELLI PROLUNGATI PER F1 – F2

Longer Nosepieces for F1 - F2

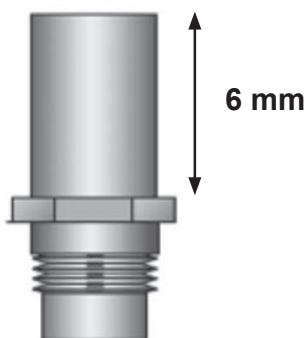

6 mm

Ø 2,4 (F1) codice / code 02UP624F1

Ø 3,0 - 3,2 (F1 - F2) codice / code 02UP632F1F2

Ø 4,0 (F1 - F2) codice / code 02UP640F1F2

Ø 4,8 (F1 - F2) codice / code 02UP648F1F2

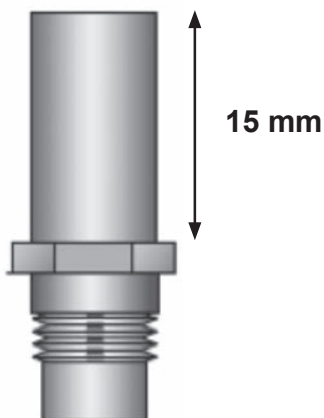

15 mm

Ø 3,0 - 3,2 (F1 - F2) codice / code 02UP1532F1F2

Ø 4,0 (F1 - F2) codice / code 02UP1540F1F2

Ø 4,8 (F1 - F2) codice / code 02UP1548F1F2

### TESTE PROLUNGATE PER F2 - F3 - F4

Extended Heads for F2 - F3 - F4

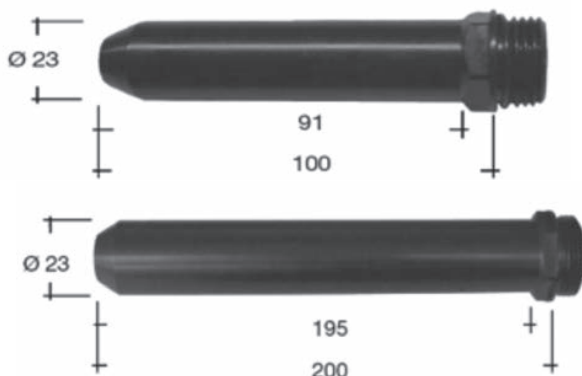

LUNGHEZZA / LENGTH 100 mm

Codice / Code 02TP100F2F3

LUNGHEZZA / LENGTH 200 mm

Codice / Code 02TP200F2F3



# RIVETTATRICI A BATTERIA PER RIVETTI A STRAPPO

BATTERY TOOLS FOR BLIND RIVETS

AKKU BLINDNIETGERÄTE

RIVETEUSES SUR BATTERIE POUR RIVETS AVEUGLES

REMACHADORAS A BATERIA PARA REMACHES

		
	<b>02RBZ</b>	<b>02RBZPLUS</b>
Dimensioni / Dimensions	270x280	270x280
Dimensione rivetti / Rivet capacity	∅ 2.4-5.0 mm	∅ 4-6.4 mm
Corsa / Stroke	22 mm.	26 mm.
Motore / Drive	18V DC	18V DC
Forza di installazione / Setting force	10.000 N	20.000 N
Capacità batteria / Battery	2.0 Ah	2.0 Ah
Durata della batteria / Long lasting battery	750 pezzi / pcs. (inox Ø 5 mm)	500 pezzi / pcs. (inox Ø 6.4 mm)
Peso con batteria / Weight including battery	1.85 Kg	1.9 Kg
Rumorosità / Noise level	78.8 dB	78.8 dB
Vibrazioni / Vibration	< 2.5 m/s <sup>2</sup>	< 2.5 m/s <sup>2</sup>
Tempo di caricamento batteria / Battery Charging Time	<80 min.	<80 min.

**SECONDA BATTERIA  
IN DOTAZIONE!**  
*Second battery included!*



270 mm

280 mm

CODICE CODE	PRODOTTO / PRODUCT
<b>02BRTZ18</b>	BATTERIA per 02RBZ e 90TBZ / BATTERY FOR 02RBZ AND 90TBZ
<b>02CLAMPJAWSRBZ</b>	MORSETTI per 02RBZ (SET 3 PEZZI) / JAWS FOR 02RBZ (SET 3 PCS)
<b>02U32RBZ</b>	UGELLI 3.2 per 02RBZ / NOSEPIECE 3.2 FOR 02RBZ
<b>02U40RBZ</b>	UGELLI 4.0 per 02RBZ / NOSEPIECE 4.0 FOR 02RBZ
<b>02U48RBZ</b>	UGELLI 4.8 per 02RBZ / NOSEPIECE 4.8 FOR 02RBZ
<b>02U64RBZ</b>	UGELLI 6.4 per 02RBZ / NOSEPIECE 6.4 FOR 02RBZ



## Fasteners for sheet metal - Fissaggi per lamiera

### THREADED INSERTS - INSERTI FILETTATI



### SELF CLINCHING FASTENERS - AUTOFISSANTI



### WELDING STUDS - PERNI A SALDARE



## Fasteners for solid parts - Fissaggi per parti solide

### SELF-TAPPING, SPECIAL AND WIRE INSERTS BUSSOLE AUTOFILETTANTI, SPECIALI E FILETTI RIPORTATI

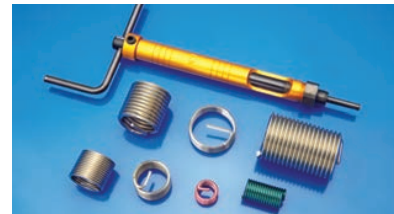

## Fasteners for plastics - Fissaggi per la plastica

### BRASS INSERTS - INSERTI IN OTTONE



## Fasteners for tubes - Fissaggi per tubi

### INSERTS FOR TUBES - INSERTI PER TUBI





**INSERTI FILETTATI**  
*THREADED INSERTS*



**AUTOFISSANTI**  
*SELF-CLINCHING  
FASTENERS*



**PERNI A SALDARE**  
*WELDING STUDS*



**FISSAGGI PER MATERIE  
PLASTICHE**  
*FASTENERS FOR PLASTICS*



**FILETTI RIPORTATI**  
*WIRE INSERTS*



**INSERTI PER TUBI**  
*INSERTS FOR TUBES*



**BUSSOLE AUTOFILETTANTI  
E SPECIALI**  
*SELF-TAPPING AND SPECIAL  
THREADED INSERTS*

# FIXI®

**FASTENING SYSTEMS**

Via Bellardi, 40/A - 10146 Torino (Italy)  
Tel. 0039 011.7072398 / 7070877 - Fax 0039 011.7072521  
E-mail: [info@fixi.it](mailto:info@fixi.it) - [www.fixi.it](http://www.fixi.it)

# FIXI® VAL

**VALLE D'AOSTA - PIEMONTE  
LOMBARDIA - LIGURIA**

Via Valgioie, 94 - 10146 Torino Italy  
Tel. 0039 011.0882009 - Fax 0039 011.0882012  
E-mail: [info@fixivpl.it](mailto:info@fixivpl.it) - [www.fixi.it](http://www.fixi.it)

# FIXI® 3V

**TRENTINO - VENETO - FRIULI**

Via Keplero, 4G/H - Z.I. di Tognana - 35028 Piove di Sacco (PD) Italy  
Tel. 0039 049.8079285 - Fax 0039 049.8087725  
E-mail: [trevenezie@fixitrevenezie.it](mailto:trevenezie@fixitrevenezie.it) - [www.fixi.it](http://www.fixi.it)

# FIXI® ets

**EMILIA ROMAGNA - TOSCANA - SARDEGNA**

Via Secci, 4 - 40132 Bologna Italy  
Tel. 0039 051.0353243 - Fax 0039 051.0353244  
E-mail: [amministrazione@fixiets.it](mailto:amministrazione@fixiets.it) - [www.fixi.it](http://www.fixi.it)

# FIXI® u.a

**MARCHE - UMBRIA - ABRUZZO - MOLISE**

Via Roma, 10 - 63078 Fr. Pagliare del Tronto Spinetoli (AP) Italy  
Tel. 0039 0736.814110 - Fax 0039 0736.984002  
E-mail: [info@fixiua.it](mailto:info@fixiua.it) - [www.fixi.it](http://www.fixi.it)

# FIXI® csi

**CENTRO SUD ITALIA**

Via Arno, 50 - 63082 Castel di Lama (AP) (ITALY)  
Tel. 0039 0736.812922 - Fax 0039 0736.812922  
E-mail: [info@fixicentrosud.it](mailto:info@fixicentrosud.it) - [www.fixi.it](http://www.fixi.it)

Member of CISQ Federation

