

# 2

## TIRAINSERTI OLEOPNEUMATICA PER INSERTI FILETTATI

OLEOPNEUMATIC TOOL FOR THREADED INSERTS

PNEUMATISCH-HYDRAULISCHES BLINDNIETMUTTERSETZGERÄT

PISTOLET OLÉO-PNEUMATIQUE POUR INSERTS FILETÉS

REMACHADORAS NEUMATICAS PARA TUERCAS REMACHABLES

CODICE Code	CARATTERISTICHE TECHNICAL FEATURES						
	DIMENSIONI DIMENSIONS	UTILIZZO USAGE	TIRANTI E TESTINE INCLUSI MANDRELS AND NOSE PIECES INCLUDED	PRESSIONE DI UTILIZZO PRESSURE REQUIRED	PESO WEIGHT	CORSA STROKE	FORZA TRACTION POWER
90F4B312	285(A) 270(H) 99(D)	M3 - M12	M4 : M10	5 - 7 BAR	1.6 Kg	7 mm	18,7 kN
90F4B312K	285(A) 270(H) 99(D)	M3 - M12	M3 : M12	5 - 7 BAR	1.6 Kg	7 mm	18,7 kN
90F5812	280(A) 270(H) 120(D)	M8 - M12	M8 : M12	5 - 7 BAR	2.23 Kg	8 mm	27 kN

CODICE CODE	PRODOTTO PRODUCT
92ATAP4M3	TIRANTE / MANDREL M3
92ATAP4M4	TIRANTE / MANDREL M4
92ATAP4M5	TIRANTE / MANDREL M5
92ATAP4M6	TIRANTE / MANDREL M6
92ATAP4M8	TIRANTE / MANDREL M8
92ATAP4M10	TIRANTE / MANDREL M10
92ATAP4M12	TIRANTE / MANDREL M12
92BUAP4M4	BUSSOLA / RIVET BOLT M4
92BUAP4M5	BUSSOLA / RIVET BOLT M5
92BUAP4M6	BUSSOLA / RIVET BOLT M6
92BUAP4M8	BUSSOLA / RIVET BOLT M8
92TEAP4M3	TESTINA / NOSE PIECE M3
92TEAP4M4	TESTINA / NOSE PIECE M4
92TEAP4M5	TESTINA / NOSE PIECE M5
92TEAP4M6	TESTINA / NOSE PIECE M6
92TEAP4M8	TESTINA / NOSE PIECE M8
92TEAP4M10	TESTINA / NOSE PIECE M10
92TEAP4M12	TESTINA / NOSE PIECE M12

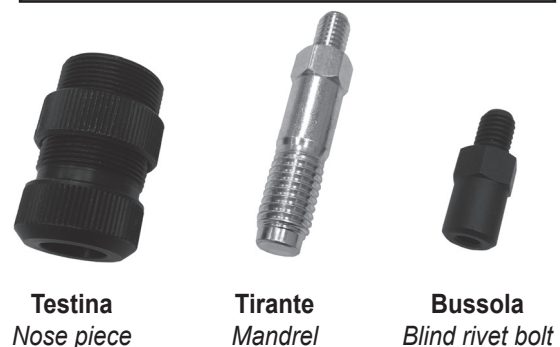
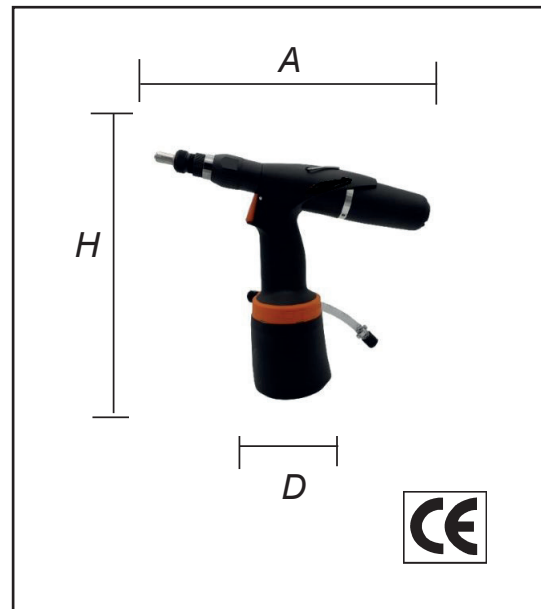

### 90F4B312K

UNA DELLE MACCHINE PIÙ VELOCI DEL MERCATO - ESTREMAMENTE LEGGERA - NON OCCORRONO CHIAVI PER SOSTITUIRE I MANDRINI. LA TIRAINSERTI INSTALLA GLI INSERTI UTILIZZANDO LA REGOLAZIONE DELLA CORSA.  
ONE OF THE FASTEST TOOL ON THE MARKET - VERY LIGHT - MANDRELS CAN BE CHANGED WITHOUT USING ANY WRENCH. TOOL TO INSTALL THE RIVET NUTS USING STROKE REGULATION.